

POMPA PER VUOTO A SECCO DRY VACUUM PUMP

3 S



Gruppo pompante in ghisa, estremamente compatto accoppiato direttamente al motore. Valvola silenziatrice in mandata.



Extremely compact cast-iron pumping unit, coupled directly to the motor. Silencing valve on the delivery side.



SPECIFICHE - SPECIFICATIONS

			50 Hz	60 Hz
Portata	Pumping speed	(Nm ³ /h)	3.5	4.2
Vuoto finale (Ass.)	Ult.vacuum (Abs)	(mbar)	150	150
Pressione finale rel.	Pressure	(Bar)	1.7	1.8
Esecuzione motore	Motor version	(V) multi tensione – multivolts	Y	380-400-415-440-460-480
		(V) 1 ~ - single phase	Δ	220-230-240-254-275
Potenza motore	Motor rating	(Kw) multi tensione – multivolts	0.25	0.25
		(Kw) 1 ~ - single phase	0.25	0.25
Nr.giri	Motor speed	giri/min - rpm	2810	3370
Rumorosità media	Noise level	(dB)	60	60
Peso max.	Max.weight	(Kg)	7	7

Salvo modifiche tecniche - We reserve the right to alter technical information.

COMPLEMENTOS DEL AIRE

DIMENSIONI - DIMENSIONS

(mm)	
A	230
B	155
C	120
D	100
E	80
F	63
G	85
H	113
L	43
M	65
O	112
P	210
R	30
Øa	1/4"
Øf	7

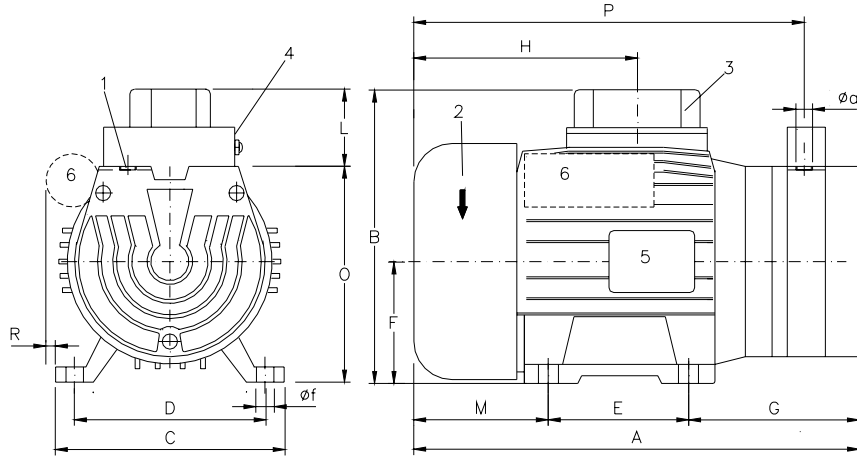

Salvo modifiche tecniche - We reserve the right to alter technical information.

1	Valvola di aspirazione	Suction valve	4	Scarico aria	Exhaust
2	Freccia senso di marcia	Rotation arrow	5	Targhetta dati	Data plate
3	Morsettiera	Wiring box	6	Condensatore	Condensator

PRESTAZIONI - PERFORMANCE CURVE

